

Item	Quantity	Part number	Description	Vendor
1	1	PRT-00481	INSPECTION FRAME	8020
2	20	ASM-00472	14057 CORNER BKT WITH HW	
3	6	ASM-00455	2020 Corner Bracket Assembly	
4	8	ASM-00482	DOUBLE CORNER BKT WITH HW	
5	1	ASM-00484	PUSH BUTTON BOX AND BRACKETS	
6	1	ASM-00507	JUNCTION BOX WITH BRACKETS	
7	1	H-4293BL	Pegboard Uline H-4293BL	U-Line
8	1	UTC-120HP-WUS1E	21.5" Ubiquitous Touch Computer	Advantech
9	4	BHCS M4X0.7X35	Socket button head screw M4x0.7 x 35 Stainless Steel	
10	4		Plain washer large grade A M4 Stainless Steel	
11	2	ASM-00488	20 SERIES ANGLE BRACKET WITH HW	
12	4	ASM-00474	CAMERA AND BRACKET ASSEMBLY	
13	2	ASM-00471	CAMERA MOUNT	
14	8	ASM-00478	LED LIGHT AND HARDWARE	
15	4	20-2570	20-2020 45 Degree Support, 320mm Long	8020

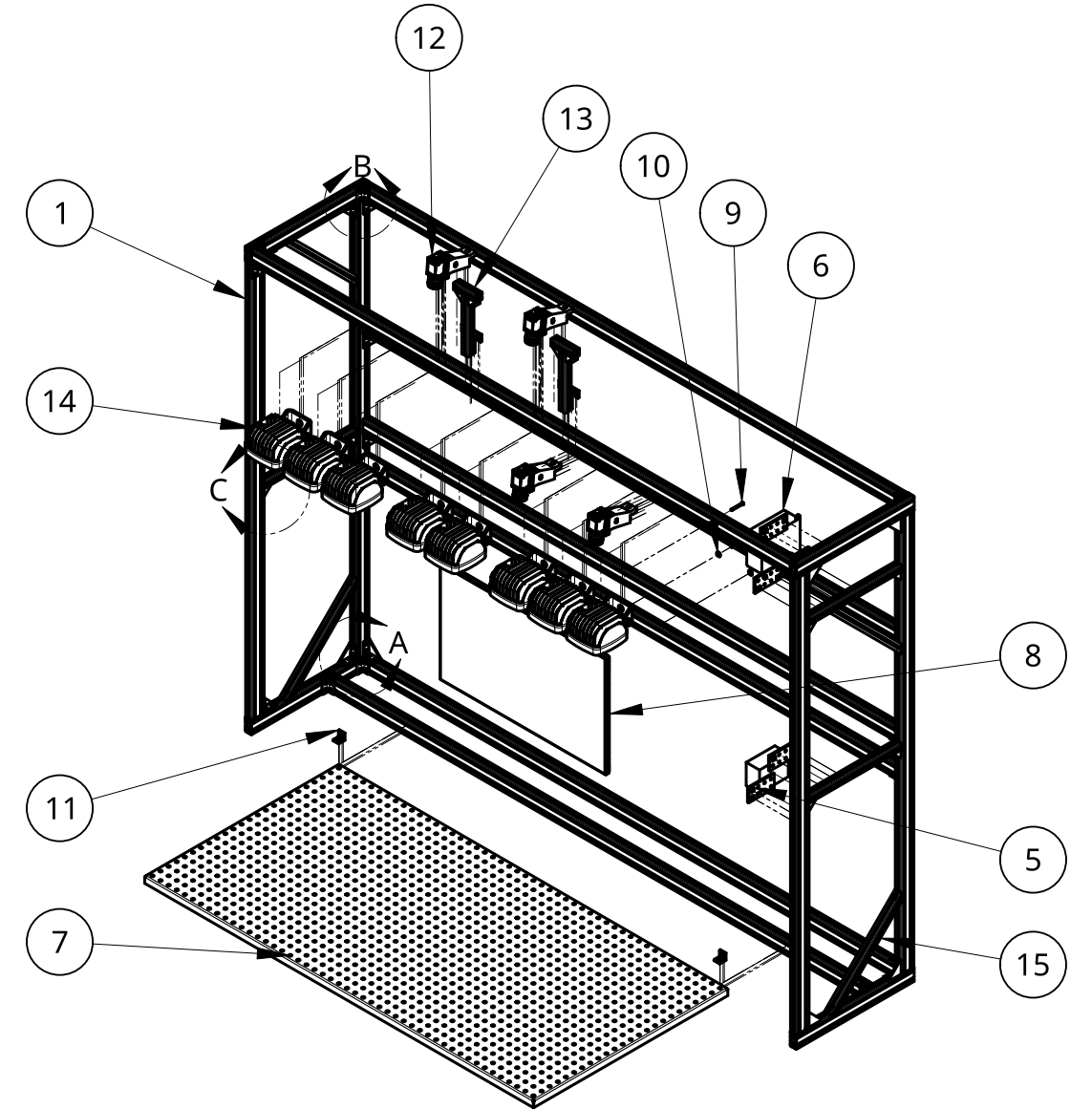

SCALE 1:16

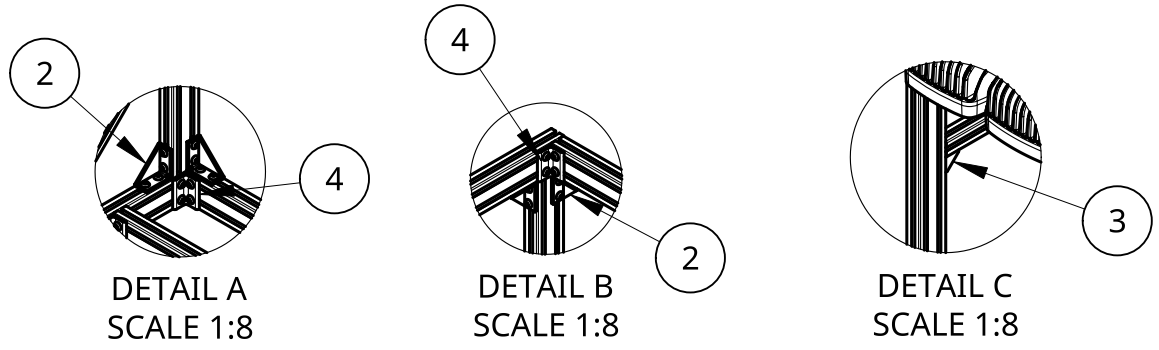

UNLESS OTHERWISE SPECIFIED, DIMENSIONS ARE IN MILLIMETERS		NAME	DATE	TITLE	
LINEAR	ANGULAR	DRAWN	MARTINB	07/16/2023	INSPECTION STAND ASSEMBLY
X ±0.5MM	X ±1°	CHECKED			
X.X ±0.1MM	X.X ±0.5°	APPROVED	MARTINB	07/17/2023	
X.XX ±0.05MM		SURFACE FINISH = 3.5um RMS		SIZE B DWG NO. ASM-00480 REV. E	
DO NOT SCALE DRAWING		MATERIAL N/A		SCALE 1:25 WEIGHT SHEET 1 of 2	
BREAK ALL SHARP EDGES AND REMOVE BURRS		FINISH			
THIRD ANGLE PROJECTION					

4

3

2

1

D

D

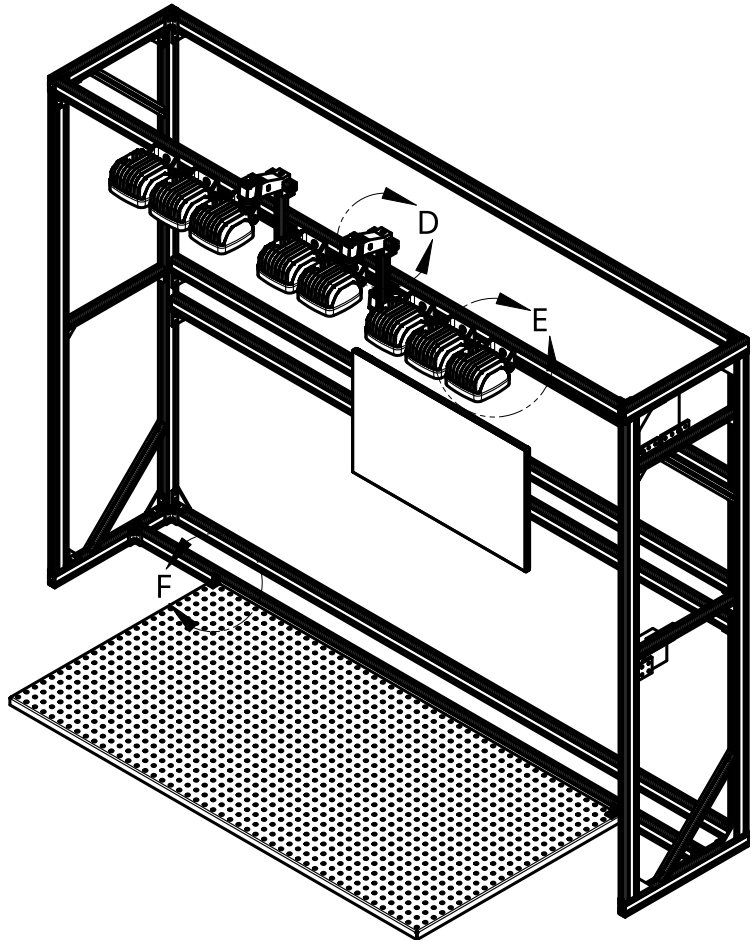

SCALE 1:16

[0] 0 [14.189] 360.4 [18.913] 480.4 [23.638] 600.4 [28] 711.2 [28.74] 730.01 [31.638] 803.6 [36.362] 923.6 [38.079] 967.2 [40] 1016 [44.362] 1126.8 [49.087] 1246.8 [53.811] 1366.8

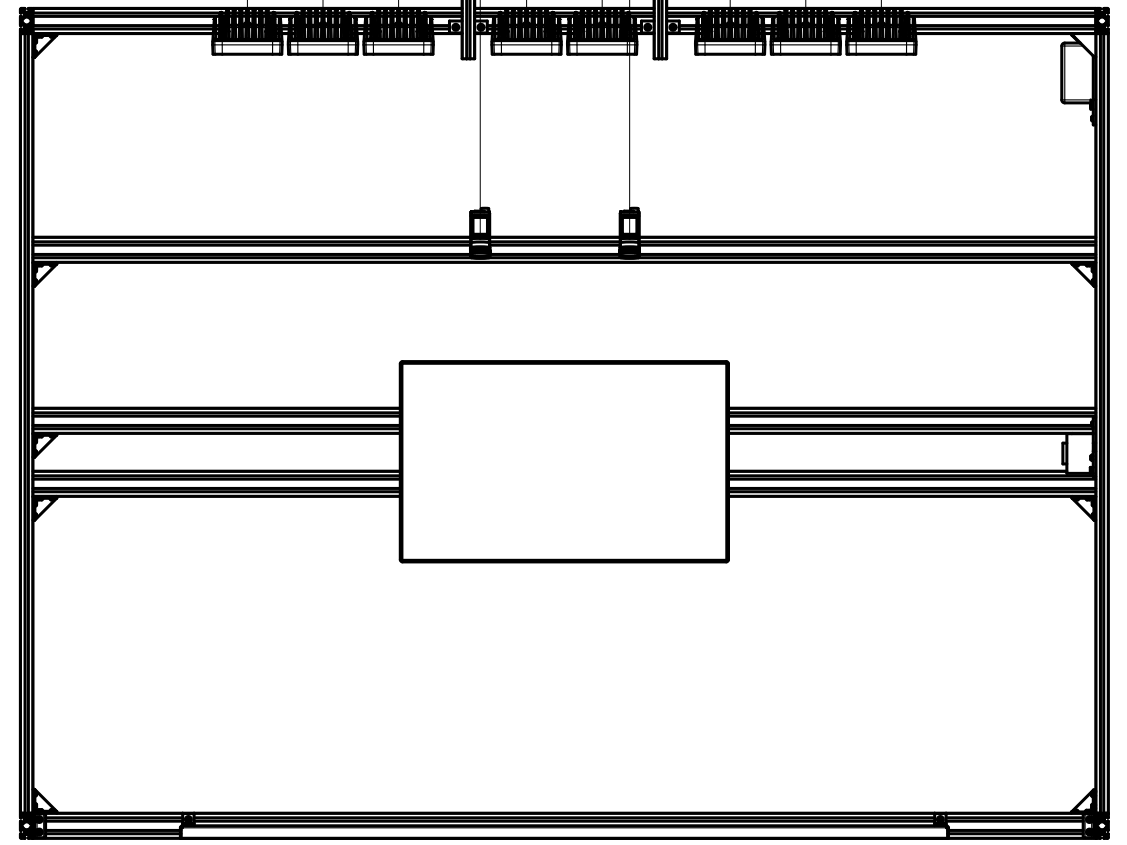

C

C

B

B

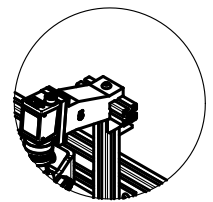

DETAIL D
SCALE 1:8

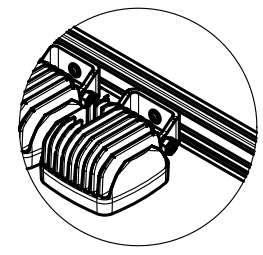

DETAIL E
SCALE 1:8

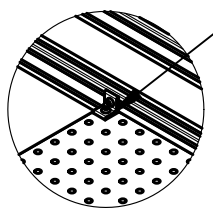

DETAIL F
SCALE 1:8

INSTALL HEX NUT FROM UNDERSIDE OF PEGBOARD

A

A

UNLESS OTHERWISE SPECIFIED,
DIMENSIONS ARE IN MILLIMETERS
LINEAR ANGULAR
X ±0.5MM X ±1°
X.X ±0.1MM X.X ±0.5°
X.XX ±0.05MM

SURFACE FINISH = 3.5um RMS

DO NOT SCALE DRAWING

BREAK ALL SHARP EDGES AND REMOVE BURRS

THIRD ANGLE PROJECTION

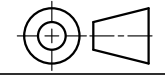

	NAME	DATE
DRAWN	MARTINB	07/16/2023
CHECKED		
APPROVED	MARTINB	07/17/2023

TITLE	INSPECTION STAND ASSEMBLY	
-------	---------------------------	--

SIZE	DWG NO.	REV.
B	ASM-00480	E

SCALE	WEIGHT	SHEET
1:12		2 of 2

4

3

2

1