

4

3

2

1

Item	Quantity	Name
1	1	TABLE MOUNT INSPECTION FRAME ASSEMBLY
2	1	21.5" Ubiquitous Touch Computer
3	4	Dovetail Camera
4	6	Plain washer normal grade A M8
5	2	Hex socket head cap screw M8x1.25 x 12
6	2	Hex socket head cap screw M8x1.25 x 40
7	4	Hex thin nut grade A & B M8
8	2	Hex socket head cap screw M8x1.25 x 25
9	1	Enclosure Electrical
10	1	Monitor arm
11	1	9054T16_Workbench
12	1	LIGHT, LED, STRIP, 24VDC, 2A, 48W, 50.79IN

REVISIONS			
Revision	Revision description	Date approved	Approver
A	INITIAL RELEASE	10/31/2023	MartinB
B	DELETE BLANK PAGE 2	10/31/2023	MartinB
C	REPLACE LED LIGHTS; REMOVE JUNCTION AND PUSH BUTTON BOX	09/06/2024	MartinB
D	DRAWING CLEANUP- UPDATE TO LATEST BENCH	09/06/2024	MartinB
E	BOM TABLE CLEANUP	09/06/2024	MartinB

NOTES:

① OPTIONAL MOUNTS TO CONNECT TO SHELVES ON WORKBENCH IF PRESENT

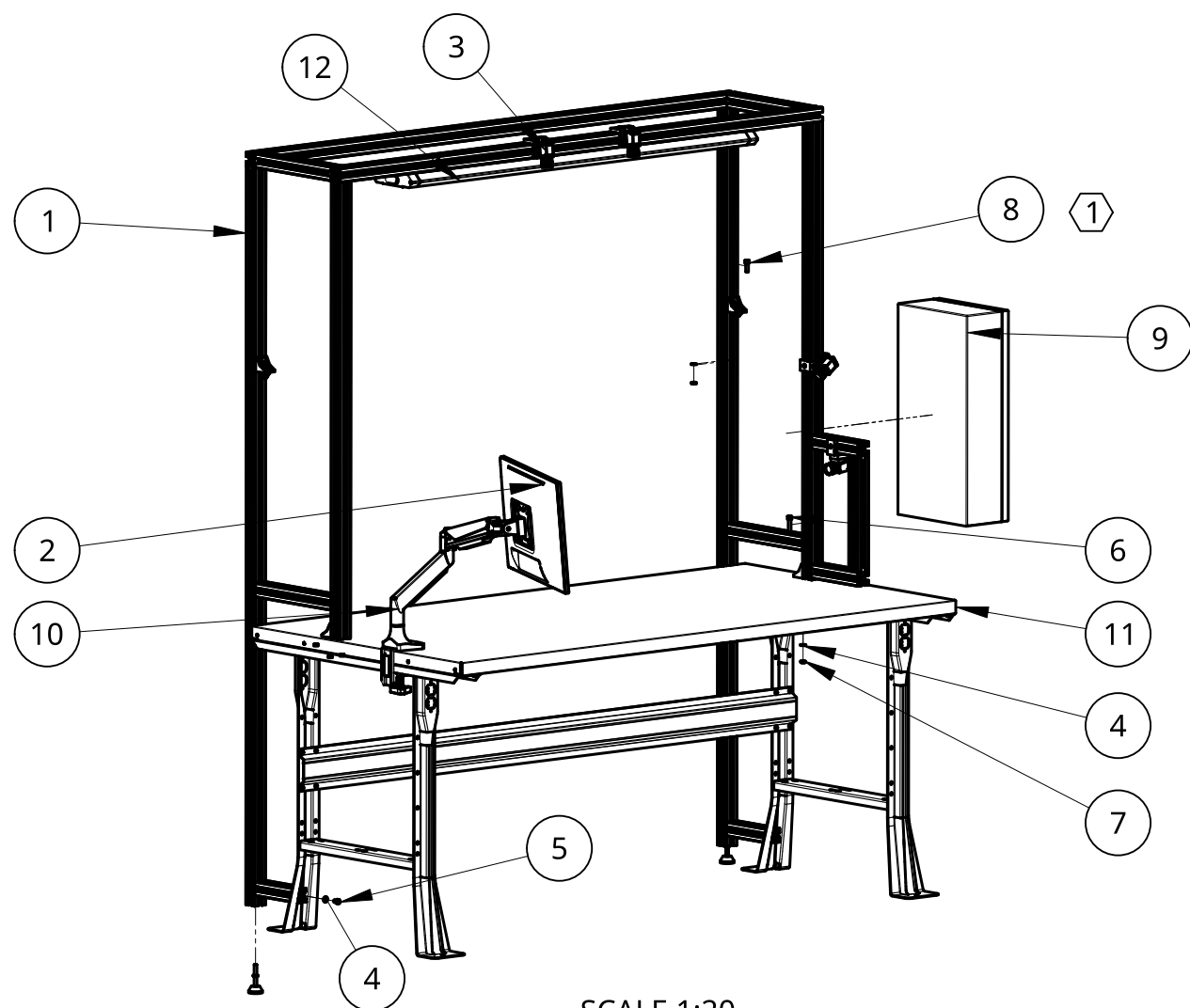

UNLESS OTHERWISE SPECIFIED,
DIMENSIONS ARE IN MILLIMETERS
LINEAR ANGULAR
X ±0.5MM X ±1 °
X.X ±0.1MM X.X ±0.5 °
X.XX ±0.05MM

SURFACE FINISH = 3.5um RMS

DO NOT SCALE DRAWING
BREAK ALL SHARP EDGES AND REMOVE BURRS
THIRD ANGLE PROJECTION

	NAME	DATE
DRAWN	MARTINB	10/31/2023
CHECKED		
APPROVED	MARTINB	09/06/2024
MATERIAL	N/A	FINISH

TITLE		INSPECTION FRAME AND WORKBENCH	
SIZE	DWG NO.	REV.	
B	ASM-00745	E	
SCALE	WEIGHT	SHEET	
1:32		1 of 1	

4

3

2

1